

PAW 3

Reliable weighing and labeling



Go to product page



Setting the standard in weigh price labeling for over 30 years

The first systems of the PAW series are still in industrial use today. Some have already printed well over 200 million labels – and continue to operate with outstanding reliability.



✓ Quality

The quality of our price labeling systems is evident not only in their solid construction, designed for maximum longevity, but also in the consistently precise print image of the labels.

✓ Reliability

Low wear and tear ensures maximum reliability. Our customers appreciate the resulting minimal downtime and low maintenance costs.

✓ Customer Satisfaction

Our systems are flexibly adapted to meet a wide range of customer requirements. In doing so, we set standards – even beyond standard applications!

✓ Sustainability

In developing our systems, we place particular emphasis on sustainability. Both resource consumption and the durability of all wear parts – and the system as a whole – are optimized. You can count on it.



Florian Mehl
Managing Partner

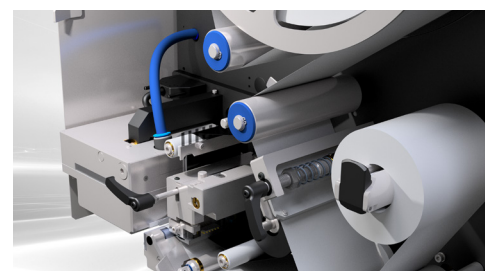
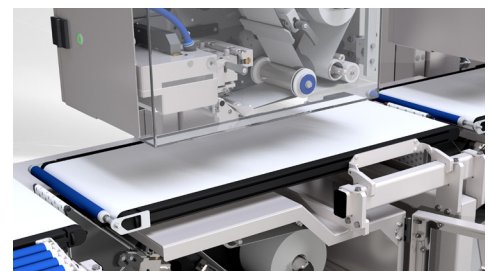

Flexible in Use

The PAW3 is available in a wide range of versions to suit different weighing ranges, product types and product dimensions. It allows for the connection of any number of additional printers, enabling labeling from the top, bottom, or laterally – in any desired combination.

- Usable as a checkweigher
- Automatic adjustment of transportation speed, labeler height and horizontal labeler position when switching products
- Automatic adjustment of label position during product changeovers
- Automatic adjustment of the air-jet applicator to the label size when switching labels
- Total and daily performance per PLU and PAW easily retrievable via integrated counters
- Various weighing ranges, machine lengths, belt dimensions and working heights for optimal adaptation to production conditions
- Optional: automatic adjustment of product guides during product changeovers
- Optional: integrated camera system for quality control of the print image

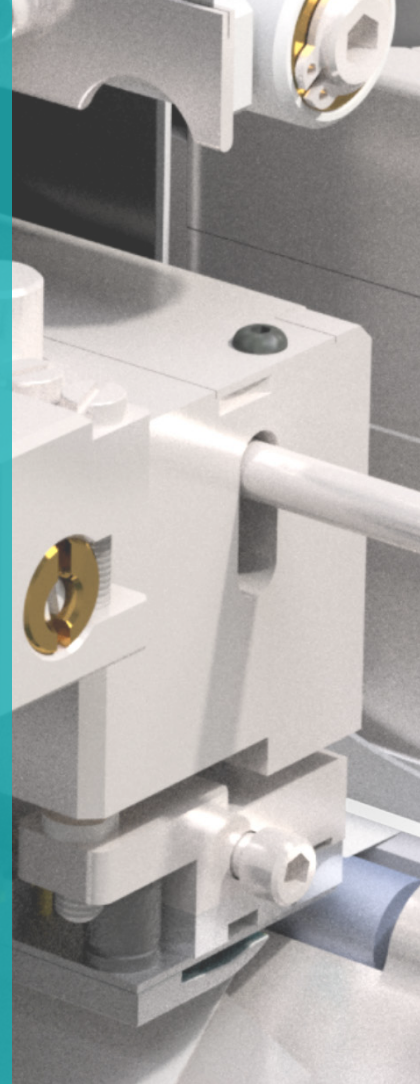

✓ Modern Technology

- Large 17" touchscreen
- Network-capable via Ethernet (TCP/IP)
- Open XML interface allows seamless integration into ERP systems
- Remote control and maintenance module available
- Optional OPC-UA interface available

✓ Easy to Operate and Maintain

- Optimal accessibility of all functional components ensures exceptionally easy maintenance and cleaning
- Modular design facilitates the replacement of functional parts

✓ Minimized Consumption

- Significantly reduced consumption values thanks to the optimized air-jet applicator

✓ Convincing User Guidance

- The PAW3 control unit enables centralized article and label management for all connected printers
- Simple and clear label design using the integrated graphic mode or optionally with the LANScale Designer application on the PC

✓ Powerful Performance

- Up to 180 labelings per minute at a print speed of up to 300 mm/s

✓ Professional Label Design

- Unicode-capable
- All common barcodes available (including 2D codes)
- Logos can be integrated at any time in any number

Application	Weigh Price Labeler Checkweigher for pre-packaged goods
Max. Load	1.875 kg / 3.750 kg / 7.500 kg
Min. Load	20 g / 40 g
Scale Interval (d)	0.5 g / 1 g / 2 g
Accuracy Classes	Y(a), XIII(1)
Machine Length	According to requirements
Working Height	850 mm +70 / -50 mm Other heights available on request
Conveyor Dimensions	Belt width: 300 mm Belt length: according to requirements
Running Direction	As required
Output	Up to 180 packages/min
Package Format (max.)	Length: 500 mm, width: 300 mm, height: 200 mm
Labeling Technology	Air-jet application from above Vacuum belt application from below
Label Format	Top: length 35–110 mm, width 35–110 mm Bottom: length 35–170 mm, width 35–110 mm
Roll Diameter	Up to 350 mm
Printing Method	Thermal direct, optional: thermal transfer
Resolution	8 dot/mm, optional: 12 dot/mm
Print Width	104 mm
Print Speed	Up to 300 mm/s
Interfaces	RS 232C, RS 422/485, Ethernet (TCP/IP), USB Other interfaces on request
Power Supply	400 V, 50 Hz
Connected Load	Approx. 1 kVA
Ambient Temperature	0°C to 40°C
Connection of Additional Devices	Any number of additional printers and standard accessories or peripheral devices

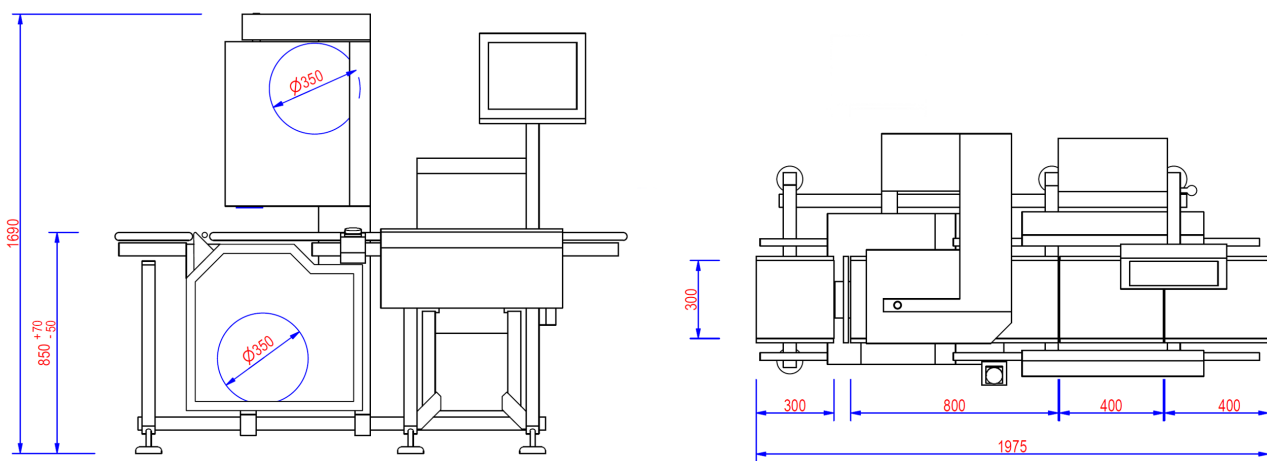

Practical Example: PAW3